



Department of Electronic and Computer Engineering of Sri Lanka Institute of Information technology is organizing a robot competition among all SLIIT students. Competition is named as “ROBOFEST 2010”.

Venue :- Sri Lanka Institute of Information Technology, Malabe Campus.

Competition Date:- 15th September 2010.

Application Deadline :- 09th July 2010.

1) ROBOT SPECIFICATIONS

The competing robots, should be self-navigating, and should perform the given track. Competitors may build their robots using any architecture. However, they should adhere to the following uidelines.

- All robot devices should conform to maximum dimensions of 250mm (Length) X 180 mm (Width) X 200 mm (Height), including all accessories.
- Robot should be provided with a start switch for the handler to commence the contest. The robots should perform the task fully-autonomously. Once the robot is switched on, any human interaction with the robot is not allowed.
- The use of external power is also not allowed.
- Robot should not collide with fence of the board or obstacles.
- Robot must be handed over to the handler at the start of the competition.

2) ENVIRONMENT SPECIFICATIONS

The work space is a 6m x 3m flat area covered by 10cm height fence. Robot working area is designed as shown in figure 01.

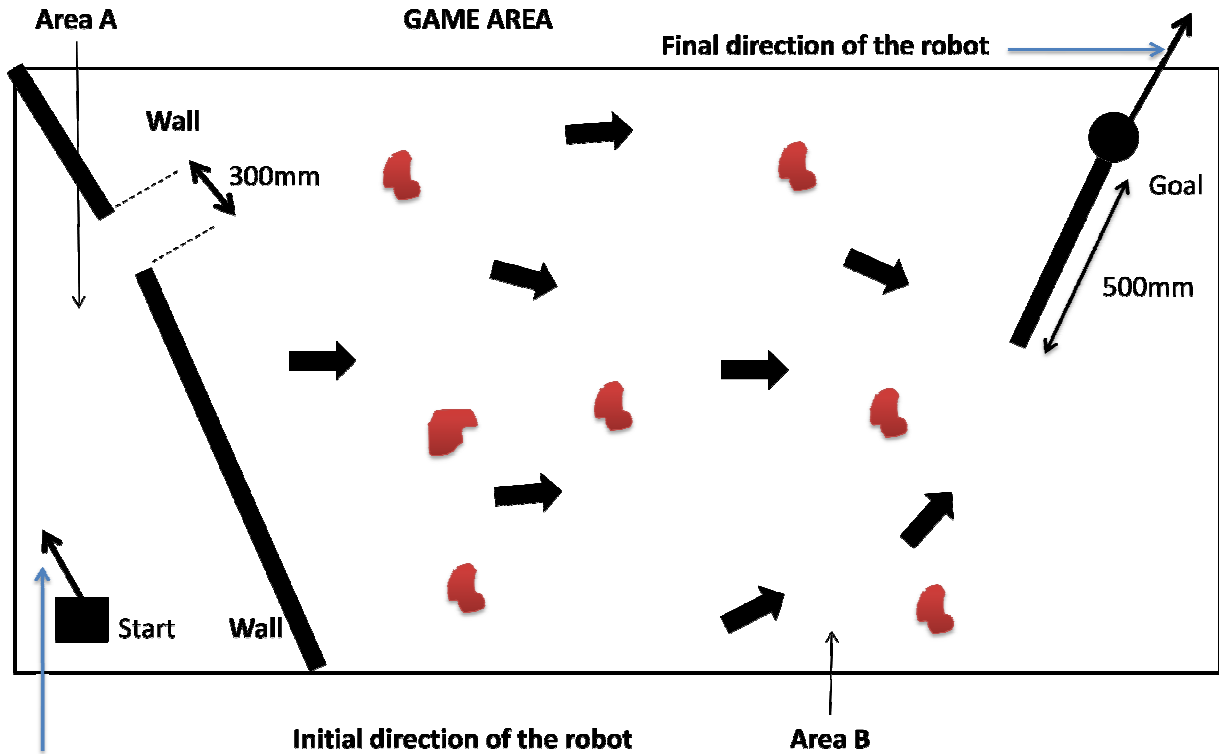

Figure 01

Robot will be placed at the start point and switched on by a handler (not a member of the robot development team). Initial direction of the Robot is given as given in the figure01. Robot must first navigate from area A to area B via the opening in the wall which is 300mm in length. In area B arrows which point towards the general direction of the goal and irregular obstacles are placed. After passing this area there is a line which is directed towards goal.

Start point

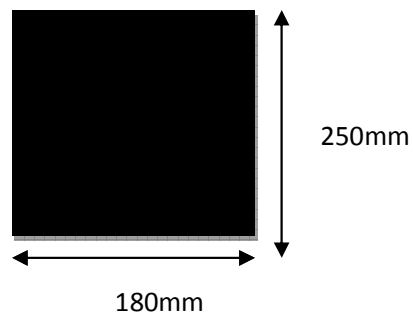

Figure 02

Goal

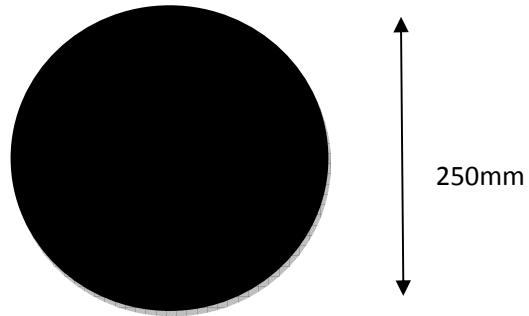

Figure 03

Final line path towards the goal

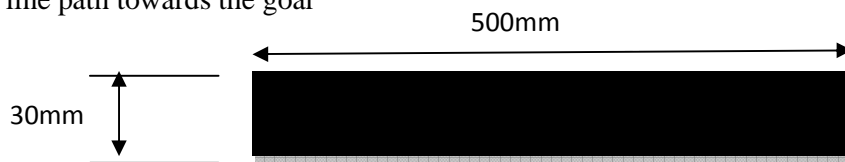

Figure 04

Arrow

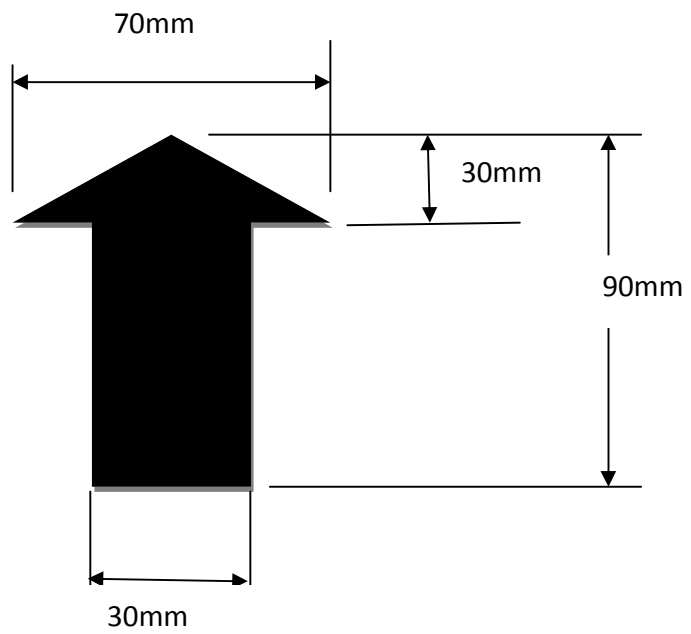

Figure 05

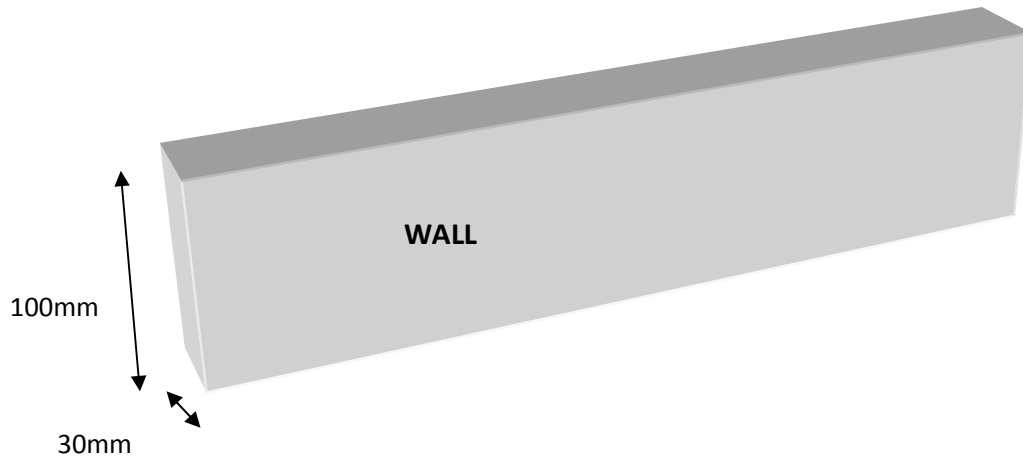

Figure 06

3) TASK

Robot should start at start point in area **A** then proceed to the area **B** . Then, robot should navigate towards the goal using arrows. Then robot should arrive at the goal aligned with the solid line. Once the robot arrives at the goal it should come to a complete halt.

4) APPLICATION

1. Group should consist of **5 current students** from the **same** academic program (i.e. Information Technology, Electronic Engineering, Computer System and Networking, Business Management Information Systems).
2. You are not allowed to form a team with members from multiple academic programs.
3. Each team should have a name which should be provided on the application.
4. . Each robot may have a sponsor who will provide financial support to develop the robot.
5. Teams may display a flags of 75mm x 100mm on the robot and decorate the robot with their sponsor's logo.
6. Students must be registered student at present
7. Completed application forms must be handed over to Dr Pradeep Abeygunawardhana at SLIIT Malabe Campus. (pradeep.a@sliit.lk) / 0112 413900 Ext 6007 on or before 9th July 2010.